

Technical Guide: R-454B Outdoor Split-System Heat Pump - XH4 3-phase



SEER2 [14.3]
EER2 [10 to 11]
HSPF IV [7.5]
Cooling capacity [34,000 to 56,000]
Heating capacity [33,500 to 57,500]

York International Corporation, 5005 York
Drive, Norman, OK 73069

6644185-UTG-C-0625
Supersedes: 6644185-UTG-B-0525

2025-06-26

Contents

Description.....	5
Certification.....	5
Features.....	6
Nomenclature.....	7
Physical and electrical data.....	8
Physical and electrical data notes.....	8
Dimensions.....	9
Dimensions table notes.....	9
System charge table upflow or horizontal left.....	10
System charge table downflow or horizontal right.....	11
System charge table notes.....	11
Charging.....	12
Applications and accessories.....	13
Sound power rating 1st stage cooling.....	14
Sound power rating 1st stage heating.....	14
Sound power rating 2nd stage cooling.....	14
Sound power rating 2nd stage heating.....	14
Mechanical specifications.....	15
Typical installation.....	16
Alternative installation clearances.....	18
Performance data 3 ton.....	19
Cooling performance data - 3 ton.....	19
Heating performance data - 3 ton.....	20
Performance data 4 ton.....	21
Cooling performance data - 4 ton.....	21
Heating performance data - 4 ton.....	22
Performance data 5 ton.....	23
Cooling performance data - 5 ton.....	23
Heating performance data - 5 ton.....	24

Description

The XH4 3-phase models are part of our successful split system heat pump lineup. These outdoor units are optimized for 14.3 SEER2/7.5 HSPF2 Minimum Efficiency in all US Regions, and are specifically designed to be matched with our residential indoor coils, furnaces, and air handlers to provide a complete system solution.

Figure 1: Installation map



Due to continuous product improvement, specifications are subject to change without notice.

Visit us on the web at www.simplygettingthejobdone.com.

Additional rating information can be found at www.ahridirectory.org.

This document is only for distribution use - it is not to be used at point of retail sale.

Certification

The units are tested in accordance with the following:

Assembled at a facility with
an ISO 9001:2015-certified
Quality Management
System



Features

- **Easier installation** - Independent panels provide quick access for unit setup. Installation time is reduced by easy power and control wiring access. All models use TXVs. The filter-drier is shipped loose for installation in the field. The unit is factory-charged for 15 ft refrigeration piping. The small base dimension and reduced unit clearances make for easier retrofits.
- **Accessible information** - QR code on unit provides quick access to technical documents and warranty information.
- **Durable finish** - The coated steel wire fan guard, coated external fasteners, and pre-treated G90-equivalent galvanized steel chassis components resist corrosion and rust creep. Powdercoat paint further protects external panels.
- **Rugged coil protection** - Coils are protected from mechanical damage by a an extruded louver coil guard.
- **Quality coils** - Enhanced aluminum fins are mechanically bonded to copper tubing.
- **Protected compressor** - Compressors are protected internally by a high pressure relief valve and a temperature sensor, and externally by the system high and low pressure switches.
- **Reliable operation** - Ball bearing fan motors provide superior performance in extreme temperatures.
- **Environmentally friendly** - CFC-free R-454B refrigerant delivers environmentally friendly performance with zero ozone depletion and a global warming potential of 467.
- **Top discharge** - Warm air is blown up, away from the structure and any landscaping and allows compact location on multi-unit applications.
- **Low operating sound levels** - Developed using CFD and FEA tools, the sturdy cabinet and top design provides sound performance as low as 69 dBA. Compatible accessories for further sound reduction are also available.
- **Better service access** - Diagonal base valves with open access for low-loss fittings, single panel access to the electrical controls, full corner access, and removable fan guard allow easy access for unit maintenance.
- **Agency listed** - Safety certified by CSA to UL 60335-2-40 4th edition. Performance certified to ANSI/AHRI Standard 210/240 in accordance with the Unitary Small Equipment certification program.

Nomenclature

Table 1: Nomenclature for AC and HP R-454B units

Number	Category	Option	Description
1	Brand	Y	YORK
		X	Private brand
		R	OTC
2	Product type	C	AC
		H	HP
3	Nominal series efficiency	3	13.4 SEER2 LGWP
		4	14.3 SEER2 LGWP
		5	15.2 SEER2 LGWP
		6	16 SEER2 LGWP
		7	17 SEER2 LGWP
		8	18 SEER2 LGWP
		9	19 SEER2 LGWP
		V	20/21 SEER2 (DOE ccHP)
		X	22/23 SEER2
4, 5	Nominal unit capacity (MBH)	18	1.5 ton
		24	2 ton
		30	2.5 ton
		36	3 ton
		42	3.5 ton
		48	4 ton
		60	5 ton
6	Refrigerant	D	TBC
		E	R-454B
7	Voltage (voltage-phase-hertz)	2	208/230-1-60
		3	208/230-3-60
		4	460-3-60
		5	575-3-60
8	Control strategy	C	Communicating
		B	Wireless (communicating)
		S	Standard (conventional)
		W	Wireless (conventional)
9	Factory option	1	Standard (no options)
		2	Future use
10	Generation	1	First generation
		2	Second generation
11	Style letter (minor revision)	A	Style A
		B	Style B

Table 2: Model nomenclature example

Number	1	2	3	4, 5	6	7	8	9	10	11
Option	X	H	4	36	E	3	S	1	1	A

Physical and electrical data

Table 3: Physical and electrical data

Outdoor unit model	XH436E3S11	XH448E3S11	XH460E3S11	XH436E4S11	XH448E4S11	XH460E4S11
Unit supply voltage	208/230 V, 3 phase, 60 Hz			460 V, 3 phase, 60 Hz		
Normal voltage range (V) ¹	187—252			432—504		
Minimum circuit ampacity (A)	11.42	18.21	19.27	5.73	9.5	9.21
Maximum overcurrent device (A) ²	15	30	30	15	15	15
Minimum overcurrent device (A) ³	15	20	20	15	15	15
Compressor type	Two-stage scroll	Two-stage scroll	Two-stage scroll	Two-stage scroll	Two-stage scroll	Two-stage scroll
Compressor rated load	8.58	13.53	14.12	4.03	7.04	6.85
Compressor locked rotor	70.0	113.4	150.0	39.0	54.8	58.0
Crankcase heater	No	No	No	No	No	No
Factory external discharge muffler	Yes	Yes	Yes	Yes	Yes	Yes
Fan diameter (in.)	22	24	24	22	24	24
Fan Motor Type	PSC	PSC	PSC	PSC	PSC	PSC
Fan motor rated HP	1/8	1/4	1/4	1/4	1/4	1/4
Fan motor rated load (A)	0.70	1.30	1.30	0.69	0.65	0.65
Fan motor nominal RPM	1075	850	850	1100	850	850
Fan motor nominal CFM	3200	4100	4000	3200	4100	4000
Coil face area (sq. ft.)	17.9	23.8	23.8	17.9	23.8	23.8
Coil rows deep	1	1	2	1	1	2
Coil fins per inch	22	22	18	22	22	18
Liquid refrigerant piping outdoor unit (field installed)	3/8	3/8	3/8	3/8	3/8	3/8
Vapor refrigerant piping outdoor unit (field installed) ⁵	3/4	7/8	1 1/8‡	3/4	7/8	1 1/8‡
Unit charge (lb-oz) ⁶	5	8 - 6	10 - 5	5	8 - 6	10 - 5
Charge (oz/ft)	0.57	0.60	0.67	0.57	0.60	0.67
Operating weight (lb)	165	221	239	165	221	239

Physical and electrical data notes

1. Rated in accordance with AHRI Standard 110-2012, utilization range A.
2. Dual element fuses or HACR circuit breaker. Maximum allowable overcurrent protection.
3. Dual element fuses or HACR circuit breaker. Minimum recommended overcurrent protection.
4. For applications with non-standard vapor line sizes, see the *Applications and accessories* section.
5. The unit charge is correct for the outdoor unit, smallest matched indoor unit, and 15 ft of refrigerant tubing. For tubing lengths other than 15 ft, add or subtract the amount of refrigerant, using the difference in actual refrigerant piping length (not the equivalent length) multiplied by the per foot value.

Dimensions

Table 4: Dimensions

Unit model	Dimensions (in.)			Refrigerant connection service valve size (in.)	
	A	B	C	Liquid	Vapor
XH436E3S11	36 1/4	29 1/4	29 1/4	3/8	3/4
XH448E3S11	39 1/2	35 1/4	31 3/4		7/8
XH460E3S11	39 1/2	35 1/4	31 3/4		7/8‡
XH436E4S11	36 1/4	29 1/4	29 1/4		3/4
XH448E4S11	39 1/2	35 1/4	31 3/4		7/8
XH460E4S11	39 1/2	35 1/4	31 3/4		7/8‡

Dimensions table notes

- All dimensions are in inches and are subject to change without notice.
- Overall height is from the bottom of the base pan to the top of the fan guard.
- Overall length and width include screw heads.
- ‡ The adapter fitting must be field-installed for the required 1 1/8 in. of refrigerant piping.

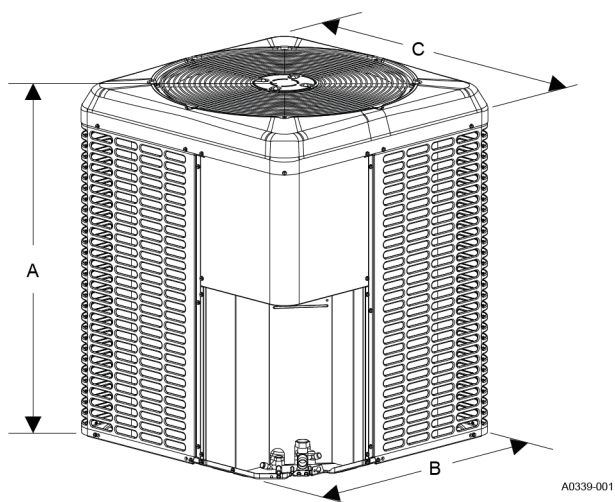
Figure 2: Dimensions

System charge table upflow or horizontal left

Table 5: System charge table upflow or horizontal left

Outdoor unit model	XH436E3S11 and XH436E4S11	XH448E3S11 and XH448E4S11	XH460E3S11 and XH460E4S11
Required metering device ^{2,3}	5C1	5C1	5C1
Indoor coil model ^{4,5,6}	Additional charge (oz) ¹		
CT(F,M,U)30*C	—	—	—
CT(F,M,U)30*D	0	—	—
CT(F,M,U)36*D	0	—	—
CT(F,M,U)48*F	4	—	—
CT(F,M,U)60*G	—	0	—
CT(F,M,U)60*H	—	1	0
CT(F,M,U)60*J	—	—	0
JHE24*C	—	—	—
JHE30*D	0	—	—
JHE36*D	0	—	—
JHE42*F	4	—	—
JHE48*G	—	0	—
JHE60*H	—	1	0
JHE60*J	—	—	0
JHC24*C	—	—	—
JHC36*D	0	—	—
JHC42*F	4	—	—
JHC48*G	—	0	—
JHC60*H	—	1	0
JHC60*J	—	—	0

System charge table downflow or horizontal right

Table 6: System charge table downflow or horizontal right

Outdoor unit model	XH436E3S11 and XH436E4S11	XH448E3S11 and XH448E4S11	XH460E3S11 and XH460E4S11
Required metering device ^{2,3}	5C1	5C1	5C1
Indoor coil model ^{4,5,6}	Additional charge (oz) ¹		
CT(F,M,U)30*C	—	—	—
CT(F,M,U)30*D	-28	—	—
CT(F,M,U)36*D	-28	—	—
CT(F,M,U)48*F	8	—	—
CT(F,M,U)60*G	—	-5	—
CT(F,M,U)60*H	—	-4	-40
CT(F,M,U)60*J	—	—	-11
JHE24*C	—	—	—
JHE30*D	-28	—	—
JHE36*D	-28	—	—
JHE42*F	8	—	—
JHE48*G	—	-5	—
JHE60*H	—	-4	-40
JHE60*J	—	—	-11
JHC24*C	—	—	—
JHC36*D	-28	—	—
JHC42*F	8	—	—
JHC48*G	—	-5	—
JHC60*H	—	-4	-40
JHC60*J	—	—	-11

System charge table notes

1. A minus number indicates that you remove charge.
2. For applications that require a TXV, use S1-1TVM*** series kit.
3. Use a TXV kit with these indoor units to obtain system performance.
4. Systems matched with furnaces or air handlers not equipped with blower-off delays may require blower time delay.
5. Do not use CTF or CTU coils in horizontal applications.
6. Charge adders shown above do not indicate that coils are rated for every application. See the performance data tables for actual performance for specified system matches. Obtain certified system ratings from <http://www.ahridirectory.org>.

Charging

1. Check the factory unit charge listed on the unit nameplate to verify the refrigerant charge for the outdoor unit, the smallest matched indoor unit, and the 15 ft of interconnecting refrigeration piping.
2. Verify the indoor metering device and additional charge required for the specific matched indoor unit in the system using [Table 5](#) and [Table 6](#).
3. Add additional charge for the amount of interconnecting refrigeration piping greater than 15 ft at the rate specified in [Table 3](#).
4. For installations requiring additional charge, weigh in refrigerant for the specific matching indoor unit and actual refrigeration piping length.
5. After weighing in the charge adders for the matched indoor unit and refrigeration piping, verify the system operation against the temperatures and pressures in the charging chart for the outdoor unit. Locate the charging charts on the outdoor unit and in the *Service Data Application Guide* on www.simplygettingthejobdone.com. Follow the subcool or superheat charging procedure in the *Installation Manual* according to the type of indoor metering device in the system, and allow 10 min after each charge adjustment for the system operation to stabilize. Record the charge adjustment made to match the charging chart.
6. Permanently stamp the unit nameplate with the total system charge defined as follows: total system charge = base charge (as shipped) + charge adder for matched indoor unit + charge adder for actual refrigeration piping length + charge adjustments to match the charging chart.

Applications and accessories

Refer to the *Price Manual* for specific model numbers.

Standard application limits*		
Maximum refrigeration piping equivalent length		80 ft
Outdoor ambient temperature limits		
Cooling operation	Maximum DB	125°F
	Minimum DB	55°F
Heating operation	Maximum DB	75°F
	Minimum DB	0°F

① **Note:** *For applications such as low ambient, reduced refrigeration piping, or long refrigeration piping, see the accessories listed in the following section.

Advanced Low Ambient Control Kit (S1-2LA06701024): Contains the necessary components and controls to allow cooling operation down to -20°F (-29°C). For use with some R-454B AC and HP models. This accessory can only be applied to models that contain a PSC outdoor fan motor.

Compressor Crankcase Heater Kit (S1-025***):** A wraparound electrical resistance heater that warms the compressor sump, reducing the chance of liquid slugging on startup. Required on all long refrigeration piping and low ambient applications. See *Price Pages* or *Source1 SmartSearch* for the correct part for each application.

Indoor TXV Kit (S1-1TVM*):** Thermal expansion valves precisely meter refrigerant for optimum performance over a wide range of conditions. See [Table 5](#) and [Table 6](#), *Price Pages*, or *Source1 Smart Search* for TXV part number for each AC and HP model.

Touch-up Paint (S1-5130153**):** Color-matched aerosol paint for touching up unit chassis and panels. See *Price Pages* or *Source1 SmartSearch* for the correct color for each application.

Compressor Sound Blanket (S1-010-07xxx-000): A field-installed dense foam cover that provides 2dBA sound level reduction. See *Price Pages* or *Source1 SmartSearch* for the correct blanket for each application.

Thermostat: Compatible thermostat controls are available through accessory sourcing. For optimum performance, these outdoor units are fully compatible with our residential Hx™ Touch Screen Thermostat available through Source1. For more information, see the thermostat section of the *Product Equipment Catalog*.

Sound power rating 1st stage cooling

Table 7: Sound power data – stage 1 – cooling – octave band sound power level (db re. 1-pW)

Outdoor unit model	Power level (Hz)								dBA	SQI
	63	125	250	500	1000	2000	4000	8000		
XH436E3S11 and XH436E4S11	71	72	70	70	66	64	60	58	72	19.0
XH448E3S11 and XH448E4S11	75	72	69	71	69	64	61	60	73	19.1
XH460E3S11 and XH460E4S11	69	76	68	70	69	65	62	62	74	19.1

Sound power rating 1st stage heating

Table 8: Sound power data – stage 1 – heating – octave band sound power level (db re. 1-pW)

Outdoor unit model	Power level (Hz)								dBA	SQI
	63	125	250	500	1000	2000	4000	8000		
XH436E3S11 and XH436E4S11	71	74	68	72	68	64	60	57	73	19.0
XH448E3S11 and XH448E4S11	73	76	70	72	69	66	62	61	74	19.1
XH460E3S11 and XH460E4S11	68	73	69	71	70	67	63	58	75	19.0

Sound power rating 2nd stage cooling

Table 9: Sound power data – stage 2 – cooling – octave band sound power level (db re. 1-pW)

Outdoor unit model	Power level (Hz)								dBA	SQI
	63	125	250	500	1000	2000	4000	8000		
XH436E3S11 and XH436E4S11	71	72	70	70	66	65	60	60	73	19.1
XH448E3S11 and XH448E4S11	75	72	69	71	69	63	62	60	74	19.1
XH460E3S11 and XH460E4S11	69	77	68	70	71	67	63	59	75	19.1

Sound power rating 2nd stage heating

Table 10: Sound power data – stage 2 – heating – octave band sound power level (db re. 1-pW)

Outdoor unit model	Power level (Hz)								dBA	SQI
	63	125	250	500	1000	2000	4000	8000		
XH436E3S11 and XH436E4S11	71	74	68	71	69	65	61	57	73	19.0
XH448E3S11 and XH448E4S11	73	76	70	72	70	66	63	60	75	19.2
XH460E3S11 and XH460E4S11	68	72	70	72	71	68	64	59	76	19.1

Mechanical specifications

Manufacture and certifications

- Units shall be assembled at a facility with an ISO 9001:2015-certified Quality Management System.
- Units shall be certified by CSA to 4th Edition of UL 60335-2-40 and performance certified to ANSI/AHRI Standard 210/240.
- Units shall be sound tested according to ANSI/AHRI Standard 270.
- Certified matched system ratings will be available for download from the AHRI online directory at <http://www.ahridirectory.org>.

Unit application

- Units shall be approved for cooling operation between 55°F and 125°F without modification.
- Units shall be approved for heating operation between 0°F and 75°F without modification.
- Units shall be approved for refrigeration piping up to 80 ft equivalent length without modification.
- Units shall be approved for installation within 6 in. of a flat vertical wall without modification, according to the instructions in the technical literature.
- Units shall be certified to the 5th Edition (2014) of the Florida Building Code for both ground-mounted and rooftop-mounted applications up to 200 ft above grade with approved mounting kit.

Unit access

- Units shall have a removable fan guard that can be removed independently of the top for interior access through the top of the unit without damaging the coil.
- Units shall have two removable stamped steel coil guards for exterior coil access.
- Units shall have a separate compartment for electrical controls that can be accessed without disturbing the unit airflow.
- Units shall have a blockoff panel that can be removed to provide interior unit access through the side of the unit.
- Units shall have a removable blockoff panel and a swing open removable electrical panel that provides sufficient interior unit access for removing the compressor through the side of the unit.

Unit construction

- Units shall be shipped completely wired, piped and assembled. Wiring pigtails shall be provided for field control wiring connections. Service valves shall be provided for field refrigerant line connections.
- Units shall be factory leak checked, run tested, and shipped with a holding charge of R-454B refrigerant.
- Unit cabinet components shall be G90 equivalent steel finished with powder-coat paint rated at a minimum of 500 h under ASTM B117 testing.
- Unit base pan shall be stamped G90 equivalent steel finished with powder-coat paint rated at a minimum of 500 h under ASTM B117 testing.
- Units shall have a single corner post opposite the electrical control box and two independently removable steel coil guard panels to optimize cabinet strength and serviceability.
- Units shall have L-shaped stamped sheet metal coil guards with interior facing extrusions for superior panel stiffness and durability from hail and other mechanical impacts.
- Units shall come with a stainless steel liquid line filter-drier that is shipped loose for installation in the field.
- Unit base valves shall be mounted diagonally on the unit base pan with service ports that provide sufficient clearance for low-loss hose fittings.
- Units shall provide a service port mounted in the base pan such that panels can be removed without moving the service port.
- Units shall be constructed with a high pressure switch and a low pressure switch for system protection.

Typical installation

- Units shall be constructed with all badging and labels applied at the factory.

Unit components

- Compressor shall be hermetic with internal electrical overload protection and internal overpressure protection.
- Compressor shall be mounted on neoprene vibration isolators that do not require the removal of transportation clips or brackets.
- Outdoor fan shall be direct drive with vertical air discharge for low sound levels.
- Outdoor fan motor shall be totally enclosed with permanently lubricated ball bearings motors approved for vertical shaft applications.
- Outdoor coil shall be air cooled and constructed of enhanced aluminum fins mechanically bonded to internally enhanced \varnothing 7mm copper tubing.

Unit warranties

- Unit manufacturer shall provide a 5-year compressor warranty without a requirement for unit registration.
- Unit manufacturer shall provide a 5-year parts warranty without a requirement for unit registration.

Typical installation

Figure 3: Typical installation

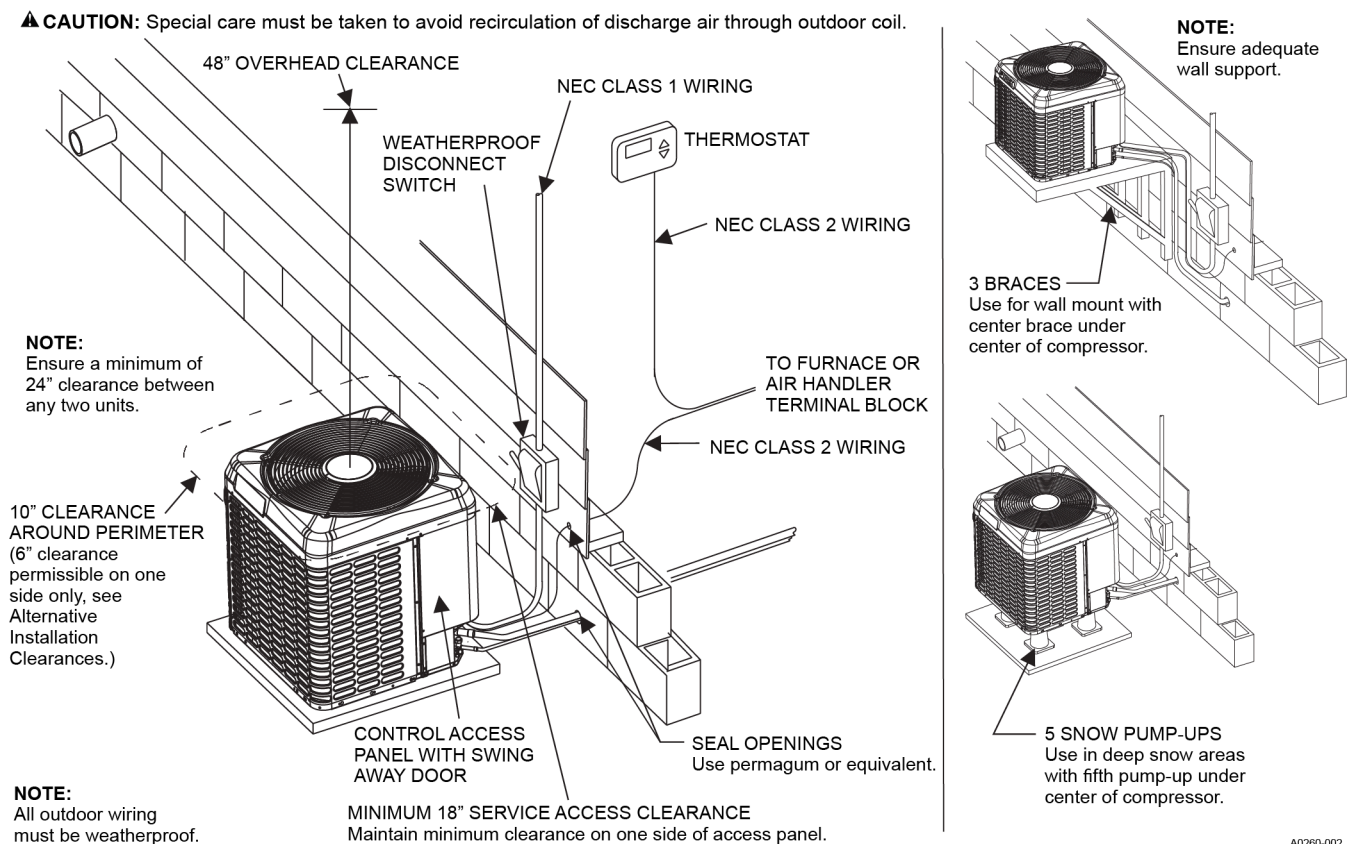

▲ CAUTION

Care must be taken to prevent ice from damaging the unit. Damage may occur from ice falling onto unit from a sloped roof or from a vertical drip line due to a partial overhang.

Figure 4: Overhang positioning

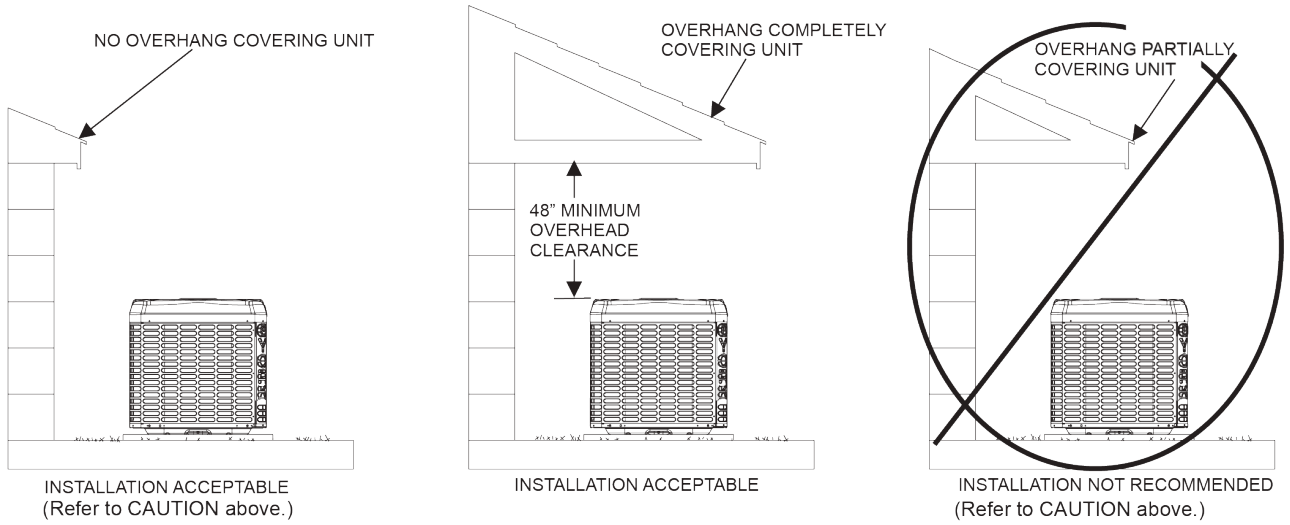

NOTE:

The unit must be installed on a solid base above the grade. The base must not be able to settle or shift causing strain on refrigerant lines and possible leaks.

NOTE:

Install unit on flat surface. If installation surface is sloped, ensure that unit slopes away from house structure at 1/4" per foot.

▲ CAUTION: Special care must be taken to avoid recirculation of discharge air through outdoor coil.

A0291-001

Alternative installation clearances

Figure 5: Alternative installation clearances

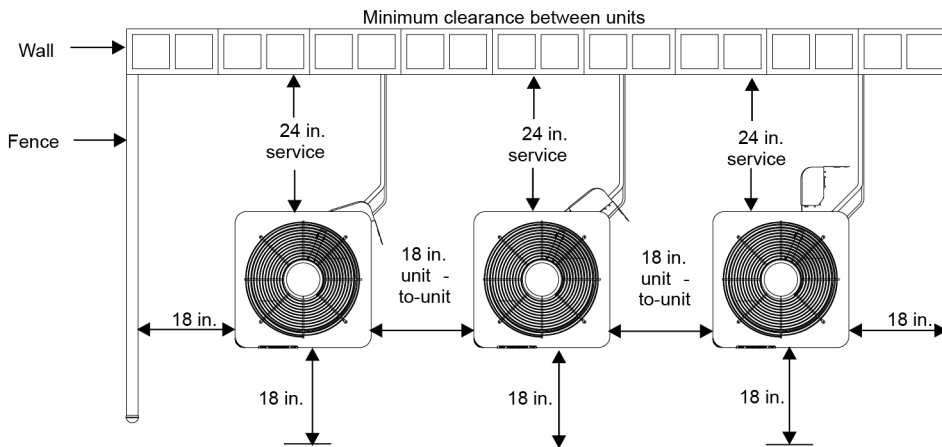

Note:
 Clearance between two units may be reduced to 18 in. minimum provided the service access clearance is increased to 24 in. minimum, and the clearance on each remaining side is maintained at 18 in. minimum.

Note:
 Clearance to one side of the unit may be reduced to 6 in. provided the clearance to each remaining side is increased to 12 in. minimum, the service access is increased to 24 in. minimum, and the clearances between any two units is maintained at 24 in. minimum.

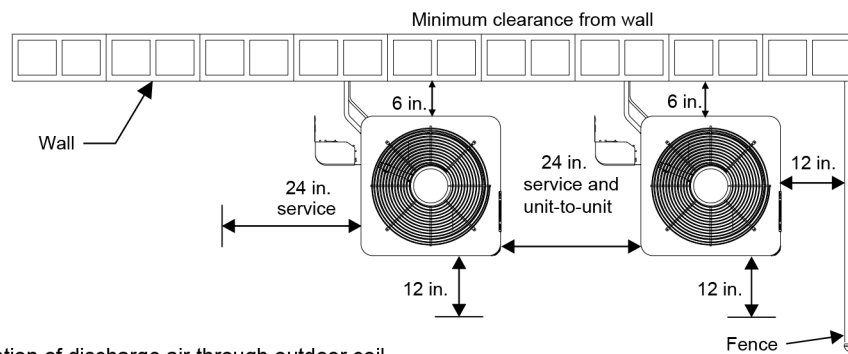

CAUTION:
 Special care must be taken to avoid recirculation of discharge air through outdoor coil.

A0287-001

Performance data 3 ton

See the following tables for performance data for the XH436E3S11 and XH436E4S11 units.

Cooling performance data - 3 ton

Table 11: Cooling performance data - 3 ton

Air temperature entering outdoor unit (°F)	Indoor CFM	900					1200					1500						
		Indoor dry bulb (°F)		80	80	75	80	80	80	80	75	80	80	80	80	75	80	80
		Indoor wet bulb (°F)		57	62	62	67	72	57	62	62	67	72	57	62	62	67	72
55	Total capacity	31.6	34.3	34.2	37.5	40.8	34.8	36.6	36.5	40.1	43.7	37.2	38.0	38.1	42.1	46.0		
	Sensible capacity	31.6	28.3	24.1	23.9	19.4	34.8	33.0	27.6	27.4	22.1	37.2	36.9	30.7	30.6	24.5		
	kW	2.09	2.12	2.12	2.16	2.21	2.27	2.29	2.29	2.33	2.38	2.44	2.44	2.44	2.49	2.54		
65	Total capacity	31.4	34.2	34.2	37.4	40.9	34.0	35.7	35.6	39.0	42.4	35.7	36.4	36.4	39.8	43.2		
	Sensible capacity	31.4	28.4	24.3	24.3	20.1	34.0	31.9	26.8	26.8	21.7	35.7	34.8	28.9	28.9	22.8		
	kW	2.25	2.28	2.28	2.32	2.36	2.41	2.43	2.43	2.47	2.52	2.57	2.58	2.58	2.62	2.67		
75	Total capacity	30.5	33.1	33.1	36.3	39.6	33.0	34.5	34.4	37.7	41.0	34.6	35.0	35.2	38.5	41.8		
	Sensible capacity	30.5	27.7	23.7	23.7	19.6	33.0	31.2	26.2	26.2	21.1	34.6	34.0	28.2	28.2	22.2		
	kW	2.44	2.47	2.47	2.50	2.54	2.60	2.62	2.62	2.65	2.69	2.76	2.76	2.76	2.80	2.84		
85	Total capacity	29.6	31.8	31.8	34.9	38.1	31.8	33.0	33.0	36.1	39.4	33.4	33.5	33.7	36.9	40.0		
	Sensible capacity	29.6	27.0	23.0	23.1	19.0	31.8	30.3	25.4	25.4	20.4	33.4	33.1	27.4	27.3	21.5		
	kW	2.66	2.69	2.69	2.72	2.76	2.82	2.84	2.84	2.87	2.91	2.98	2.98	2.98	3.02	3.05		
95	Total capacity	28.4	30.4	30.4	33.3	36.3	30.5	31.4	31.4	34.4	37.5	31.9	31.9	32.0	35.0	38.0		
	Sensible capacity	28.4	26.2	22.3	22.3	18.3	30.5	29.6	24.6	24.5	19.6	31.9	31.9	26.4	26.4	20.7		
	kW	2.92	2.94	2.94	2.98	3.01	3.08	3.09	3.09	3.13	3.16	3.23	3.23	3.24	3.27	3.30		
105	Total capacity	27.2	28.8	28.8	31.6	34.4	29.1	29.6	29.7	32.5	35.4	30.3	30.3	30.1	32.9	35.8		
	Sensible capacity	27.2	25.3	21.4	21.5	17.5	29.1	28.4	23.6	23.6	18.8	30.3	30.3	25.4	25.4	19.8		
	kW	3.21	3.23	3.23	3.27	3.30	3.37	3.38	3.38	3.41	3.45	3.52	3.52	3.52	3.56	3.59		
115	Total capacity	25.9	26.9	27.0	29.7	32.3	27.5	27.6	27.8	30.4	33.1	28.6	28.6	28.1	30.7	33.5		
	Sensible capacity	25.9	24.4	20.5	20.6	16.7	27.5	27.3	22.6	22.6	17.9	28.6	28.6	24.4	24.3	18.8		
	kW	3.54	3.56	3.56	3.59	3.63	3.70	3.70	3.71	3.74	3.78	3.85	3.85	3.85	3.88	3.92		
125	Total capacity	21.6	23.1	23.1	26.6	30.7	24.5	25.3	24.9	28.2	32.0	26.9	27.5	26.2	29.5	32.8		
	Sensible capacity	21.6	21.8	17.9	18.5	16.3	24.5	25.3	21.5	21.5	17.8	26.9	27.5	25.1	24.7	18.9		
	kW	3.92	3.91	3.92	3.95	3.99	4.08	4.08	4.07	4.10	4.14	4.23	4.23	4.21	4.25	4.28		

Heating performance data - 3 ton

Table 12: Heating performance data - 3 ton

Air temperature entering outdoor unit (°F)	Air temperature entering indoor unit (°F)	900			1200			1500		
		MBH	COP	KW	MBH	COP	KW	MBH	COP	KW
60	60	38.40	4.22	2.66	38.50	4.32	2.61	38.50	4.42	2.56
60	70	37.90	3.81	2.92	38.10	3.91	2.86	38.30	4.02	2.79
60	80	37.40	3.46	3.17	37.70	3.56	3.10	38.00	3.67	3.03
47	60	32.90	3.81	2.53	33.10	3.88	2.50	33.20	3.96	2.46
47	70	32.50	3.44	2.77	32.70	3.51	2.73	32.90	3.59	2.68
47	80	32.10	3.13	3.01	32.30	3.20	2.96	32.50	3.28	2.91
40	60	29.90	3.56	2.47	30.10	3.62	2.44	30.40	3.68	2.42
40	70	29.40	3.21	2.68	29.70	3.28	2.65	30.00	3.35	2.62
40	80	28.90	2.92	2.90	29.30	3.00	2.87	29.70	3.07	2.83
30	60	26.60	3.30	2.37	26.90	3.34	2.36	27.10	3.38	2.35
30	70	26.20	2.97	2.59	26.40	3.01	2.57	26.60	3.06	2.54
30	80	25.70	2.68	2.81	25.90	2.74	2.78	26.10	2.79	2.74
17	60	22.10	2.83	2.28	22.20	2.85	2.28	22.40	2.87	2.29
17	70	21.20	2.49	2.50	21.50	2.53	2.49	21.80	2.56	2.49
17	80	20.40	2.20	2.71	20.80	2.25	2.70	21.20	2.30	2.70
10	60	19.30	2.56	2.21	19.60	2.60	2.21	20.00	2.65	2.22
10	70	18.80	2.29	2.41	19.40	2.35	2.41	19.90	2.42	2.41
10	80	18.30	2.06	2.61	19.10	2.15	2.61	19.90	2.24	2.60
0	60	15.90	2.10	2.22	16.30	2.14	2.23	16.60	2.17	2.25
0	70	16.00	1.93	2.43	16.20	1.94	2.45	16.30	1.94	2.46
0	80	16.10	1.79	2.65	16.10	1.77	2.66	16.00	1.75	2.68

Performance data 4 ton

See the following tables for performance data for the XH448E3S11 and XH448E4S11 unit.

Cooling performance data - 4 ton

Table 13: Cooling performance data - 4 ton

Air temperature entering outdoor unit (°F)	Indoor CFM	1200					1600					2000						
		Indoor dry bulb (°F)		80	80	75	80	80	80	80	75	80	80	80	80	75	80	80
		Indoor wet bulb (°F)		57	62	62	67	72	57	62	62	67	72	57	62	62	67	72
55	Total capacity	44.4	48.6	48.5	52.8	57.5	47.9	50.9	50.7	55.3	59.9	50.4	52.1	52.0	56.6	61.3		
	Sensible capacity	44.3	39.1	33.7	33.4	27.7	47.9	43.8	37.0	36.9	29.8	50.4	47.9	39.8	39.6	31.4		
	kW	2.73	2.77	2.77	2.80	2.84	2.94	2.97	2.97	3.01	3.05	3.15	3.16	3.16	3.20	3.24		
65	Total capacity	43.0	46.6	46.6	50.7	55.0	46.4	48.6	48.5	52.8	57.1	48.6	49.6	49.6	53.9	58.3		
	Sensible capacity	43.0	38.3	32.8	32.6	26.7	46.4	43.1	36.2	36.0	28.8	48.6	47.3	39.1	38.9	30.4		
	kW	2.98	3.01	3.01	3.05	3.09	3.19	3.21	3.21	3.25	3.29	3.39	3.40	3.40	3.44	3.48		
75	Total capacity	41.5	44.6	44.5	48.5	52.6	44.7	46.3	46.3	50.4	54.5	46.8	47.0	47.2	51.3	55.4		
	Sensible capacity	41.5	37.4	31.9	31.7	25.7	44.7	42.4	35.4	35.2	27.8	46.8	46.6	38.4	38.1	29.5		
	kW	3.26	3.29	3.29	3.33	3.37	3.47	3.49	3.49	3.53	3.57	3.68	3.68	3.68	3.72	3.76		
85	Total capacity	40.1	42.5	42.4	46.2	50.1	43.0	43.9	44.0	47.8	51.7	44.9	45.0	44.8	48.5	52.5		
	Sensible capacity	40.1	36.7	31.0	30.8	24.7	43.0	41.8	34.6	34.4	26.9	44.9	45.0	37.7	37.4	28.6		
	kW	3.58	3.60	3.60	3.64	3.68	3.79	3.80	3.80	3.84	3.89	3.99	3.99	3.99	4.03	4.08		
95	Total capacity	38.6	40.3	40.4	43.9	47.5	41.3	41.5	41.7	45.2	48.9	43.0	43.0	42.1	45.6	49.5		
	Sensible capacity	38.6	36.0	30.2	30.0	23.9	41.3	41.1	33.9	33.7	26.0	43.0	43.0	37.1	37.1	27.8		
	kW	3.92	3.94	3.95	3.99	4.04	4.14	4.14	4.15	4.19	4.24	4.34	4.35	4.33	4.38	4.43		
105	Total capacity	36.9	38.2	38.1	41.4	44.8	39.4	39.4	39.1	42.4	45.9	40.9	40.9	39.5	42.8	46.4		
	Sensible capacity	36.9	35.1	29.4	29.2	23.0	39.4	39.4	33.2	32.9	25.1	40.9	40.9	36.5	36.2	27.0		
	kW	4.32	4.34	4.34	4.39	4.43	4.54	4.54	4.54	4.59	4.64	4.75	4.75	4.73	4.77	4.83		
115	Total capacity	35.0	35.7	35.7	38.8	42.0	37.3	37.3	36.5	39.6	42.9	38.6	38.6	36.7	39.9	43.1		
	Sensible capacity	35.0	34.2	28.4	28.2	22.0	37.3	37.3	32.2	32.0	24.2	38.6	38.6	35.7	35.4	26.1		
	kW	4.77	4.78	4.78	4.84	4.89	4.99	4.99	4.98	5.04	5.09	5.20	5.20	5.17	5.23	5.29		
125	Total capacity	33.0	33.0	33.0	35.8	38.9	34.9	35.0	33.5	36.6	39.6	36.1	36.1	33.9	36.6	39.7		
	Sensible capacity	33.0	33.0	27.4	27.1	20.9	34.9	35.0	31.3	31.1	23.2	36.1	36.1	33.9	34.6	25.1		
	kW	5.28	5.28	5.28	5.34	5.41	5.51	5.51	5.48	5.54	5.61	5.72	5.72	5.68	5.73	5.80		

Heating performance data - 4 ton

Table 14: Heating performance data - 4 ton

Air temperature entering outdoor unit (°F)	Air temperature entering indoor unit (°F)	1200			1600			2000		
		MBH	COP	KW	MBH	COP	KW	MBH	COP	KW
60	60	57.20	4.21	3.99	58.40	4.36	3.93	59.50	4.51	3.86
60	70	55.60	3.75	4.35	57.00	3.92	4.26	58.40	4.09	4.18
60	80	54.00	3.36	4.70	55.60	3.54	4.60	57.20	3.73	4.49
47	60	48.40	3.82	3.72	49.50	3.90	3.72	50.60	3.99	3.72
47	70	47.50	3.38	4.12	48.70	3.50	4.08	49.80	3.62	4.03
47	80	46.50	3.01	4.52	47.80	3.16	4.43	49.10	3.31	4.34
40	60	43.70	3.59	3.57	44.80	3.64	3.61	45.80	3.68	3.65
40	70	43.10	3.16	4.00	44.20	3.26	3.97	45.20	3.36	3.95
40	80	42.50	2.81	4.43	43.60	2.94	4.34	44.70	3.08	4.25
30	60	38.70	3.20	3.54	39.30	3.24	3.56	40.00	3.29	3.57
30	70	38.00	2.88	3.86	38.70	2.93	3.87	39.50	2.99	3.88
30	80	37.20	2.61	4.18	38.10	2.67	4.18	38.90	2.73	4.18
17	60	31.60	2.81	3.30	32.70	2.85	3.36	33.70	2.89	3.42
17	70	30.50	2.49	3.58	31.50	2.54	3.63	32.60	2.59	3.69
17	80	29.30	2.23	3.85	30.40	2.28	3.90	31.50	2.33	3.95
10	60	27.50	2.53	3.18	28.60	2.56	3.27	29.60	2.59	3.35
10	70	26.40	2.25	3.45	27.40	2.28	3.52	28.50	2.32	3.60
10	80	25.30	2.00	3.71	26.30	2.04	3.78	27.40	2.08	3.86
0	60	23.70	2.20	3.15	24.30	2.20	3.24	25.00	2.20	3.33
0	70	23.20	1.98	3.44	23.80	1.98	3.51	24.30	1.98	3.59
0	80	22.80	1.80	3.72	23.20	1.80	3.78	23.60	1.80	3.85

Performance data 5 ton

See the following tables for performance data for the XH460E3S11 and XH460E4S11 unit.

Cooling performance data - 5 ton

Table 15: Cooling performance data - 5 ton

Air temperature entering outdoor unit (°F)	Indoor CFM	1500					1750					2000						
		Indoor dry bulb (°F)		80	80	75	80	80	80	80	75	80	80	80	80	75	80	80
		Indoor wet bulb (°F)		57	62	62	67	72	57	62	62	67	72	57	62	62	67	72
55	Total capacity	55.7	58.6	58.3	60.5	61.4	59.0	60.4	59.9	62.7	64.0	61.1	61.8	61.3	64.1	65.0		
	Sensible capacity	55.7	48.5	41.5	39.0	29.3	59.0	51.8	44.0	41.3	30.9	61.1	55.0	46.2	42.8	31.3		
	kW	3.40	3.44	3.43	3.46	3.48	3.54	3.57	3.56	3.60	3.62	3.67	3.69	3.69	3.72	3.75		
65	Total capacity	51.5	55.5	54.9	60.1	64.6	53.7	56.8	56.4	61.5	66.1	55.4	57.7	57.4	62.4	67.0		
	Sensible capacity	51.5	46.1	39.2	39.2	32.1	53.7	49.0	41.3	41.1	33.2	55.4	51.8	43.0	42.9	34.2		
	kW	3.75	3.79	3.79	3.83	3.87	3.88	3.91	3.91	3.95	4.00	4.01	4.03	4.03	4.08	4.12		
75	Total capacity	50.5	54.1	53.6	58.6	63.3	52.5	55.2	54.9	59.9	64.5	54.2	55.9	55.8	60.8	65.5		
	Sensible capacity	50.5	45.7	38.8	38.7	31.7	52.5	48.8	40.9	40.8	32.9	54.2	51.7	42.8	42.7	33.8		
	kW	4.11	4.15	4.15	4.20	4.25	4.25	4.27	4.27	4.32	4.37	4.38	4.39	4.40	4.45	4.50		
85	Total capacity	49.2	52.4	52.0	56.9	61.5	51.3	53.4	53.2	58.0	62.6	52.8	54.0	54.0	58.8	63.5		
	Sensible capacity	49.2	45.3	38.2	38.2	31.2	51.3	48.5	40.4	40.3	32.4	52.8	51.1	42.4	42.2	33.4		
	kW	4.50	4.53	4.53	4.59	4.65	4.64	4.66	4.66	4.72	4.77	4.77	4.78	4.79	4.84	4.90		
95	Total capacity	47.8	50.3	50.1	54.8	59.3	49.7	51.1	51.1	55.8	60.3	51.2	51.6	51.8	56.4	61.0		
	Sensible capacity	47.8	44.6	37.7	37.6	30.5	49.7	47.8	39.7	39.7	31.7	51.2	50.8	41.7	41.6	32.8		
	kW	4.93	4.96	4.96	5.02	5.09	5.07	5.08	5.09	5.15	5.21	5.20	5.20	5.21	5.27	5.34		
105	Total capacity	46.2	47.9	47.9	52.3	56.8	47.9	48.6	48.6	53.2	57.6	49.3	49.4	49.3	53.8	58.2		
	Sensible capacity	46.2	44.0	36.8	36.8	29.7	47.9	47.0	38.9	39.0	30.9	49.3	49.4	41.0	40.9	32.0		
	kW	5.41	5.43	5.44	5.51	5.58	5.55	5.56	5.57	5.64	5.71	5.69	5.69	5.69	5.76	5.83		
115	Total capacity	44.2	45.1	45.4	49.5	53.9	45.8	45.8	46.0	50.2	54.6	47.0	47.0	46.3	50.7	55.0		
	Sensible capacity	44.2	43.0	35.9	35.8	28.7	45.8	45.8	38.1	37.9	30.0	47.0	47.0	40.3	40.0	31.1		
	kW	5.96	5.97	5.98	6.05	6.13	6.10	6.10	6.10	6.18	6.26	6.24	6.24	6.23	6.30	6.38		
125	Total capacity	40.7	40.9	41.1	45.4	51.9	42.0	42.2	41.5	47.0	52.5	43.0	43.3	41.7	48.4	52.9		
	Sensible capacity	40.7	40.8	33.8	33.8	28.6	42.0	42.2	36.2	36.9	29.8	43.0	43.3	38.4	40.0	30.9		
	kW	6.61	6.60	6.60	6.67	6.75	6.75	6.74	6.73	6.80	6.87	6.89	6.88	6.85	6.93	7.00		

Heating performance data - 5 ton

Table 16: Heating performance data - 5 ton

Air temperature entering outdoor unit (°F)	Air temperature entering indoor unit (°F)	1500			1750			2000		
		MBH	COP	KW	MBH	COP	KW	MBH	COP	KW
60	60	68.50	3.99	5.03	68.60	4.08	4.93	68.70	4.18	4.82
60	70	67.60	3.59	5.52	67.90	3.68	5.40	68.30	3.79	5.28
60	80	66.70	3.25	6.01	67.20	3.35	5.88	67.80	3.46	5.74
47	60	58.70	3.60	4.78	59.00	3.67	4.71	59.20	3.74	4.64
47	70	58.00	3.24	5.24	58.30	3.31	5.15	58.60	3.39	5.07
47	80	57.30	2.94	5.70	57.60	3.01	5.60	57.90	3.09	5.50
40	60	53.40	3.36	4.65	53.80	3.42	4.60	54.10	3.48	4.55
40	70	52.50	3.03	5.07	53.00	3.10	5.01	53.50	3.17	4.96
40	80	51.60	2.75	5.49	52.30	2.82	5.43	52.90	2.89	5.36
30	60	47.50	3.12	4.46	47.90	3.16	4.44	48.30	3.20	4.42
30	70	46.70	2.80	4.89	47.10	2.85	4.84	47.40	2.89	4.80
30	80	45.90	2.53	5.32	46.20	2.58	5.25	46.50	2.63	5.18
17	60	39.60	2.79	4.17	39.90	2.80	4.17	40.20	2.82	4.18
17	70	38.10	2.45	4.57	38.60	2.48	4.57	39.10	2.51	4.56
17	80	36.60	2.16	4.97	37.30	2.21	4.96	38.00	2.25	4.95
10	60	34.60	2.52	4.03	35.30	2.56	4.04	36.00	2.60	4.05
10	70	33.80	2.24	4.41	34.80	2.31	4.41	35.80	2.38	4.41
10	80	33.00	2.02	4.79	34.30	2.10	4.78	35.70	2.19	4.77
0	60	30.40	2.30	3.87	31.00	2.34	3.89	31.70	2.37	3.92
0	70	30.60	2.11	4.25	30.90	2.12	4.28	31.20	2.12	4.30
0	80	30.80	1.95	4.63	30.70	1.93	4.66	30.60	1.91	4.69