

Technical Guide: LX Series XC3 Models - 13.4 SEER2 Split-System Air Conditioner - Three-Phase

R-454B - 3 nominal ton to 5 nominal ton



SEER2 [13.40 to 14.25]

EER2 [11 to 12]

Cooling capacity [33400 to 57000]

York International Corporation, 5005 York
Drive, Norman, OK 73069

6643521-UTG-B-0725
Supersedes: 6643521-UTG-A-0425

2025-07-31

Contents

Description.....	5
Certification.....	5
Warranty summary.....	5
Features.....	6
Nomenclature.....	7
Physical and electrical data.....	8
Physical and electrical data notes.....	8
Dimensions.....	9
Illustration of dimensions.....	9
Dimensions data notes.....	9
System charge table.....	10
System charge data notes.....	10
Charging.....	11
Applications and accessories.....	11
Sound power rating.....	12
Mechanical specifications.....	13
Typical installation.....	15
Alternative installation clearances.....	16
Performance data - 3 ton.....	17
Cooling performance data - 3 ton.....	17
Performance data - 4 ton.....	18
Cooling performance data - 4 ton.....	18
Performance data - 5 ton.....	19
Cooling performance data - 5 ton.....	19
Third-party trademarks.....	19

Description

The XC3 3-phase models are part of our successful 13.4 SEER2 Regional Minimum Efficiency product line available in the United States and Canada. These outdoor units are specifically designed to be matched with our residential indoor coils, furnaces, and air handlers to provide a complete system solution.

Figure 1: Installation map

FOR INSTALLATION IN ALL US REGIONS AND CANADA



Due to continuous product improvement, specifications are subject to change without notice.

Visit us on the web at www.simplygettingthejobdone.com.

Additional rating information can be found at www.ahridirectory.org.

This document is only for distribution use - it is not to be used at point of retail sale.

Certification



Assembled at a facility with
an ISO 9001:2015-certified
Quality Management
System

Warranty summary

Standard 1-year limited parts warranty.

Standard 5-year limited compressor warranty.

The warranty does not apply to R-22 models, three-phase models, or internet sales.

Refer to the limited warranty certificate in the *User's Information Manual* for details.

Features

- **Small footprint** - Minimum footprint for easier handling, transportation, and installation.
- **Easier installation** - Independent panels provide quick access for unit setup. Installation time is reduced by easy power and control wiring access. Select indoor matches with factory-mounted TXVs are available for quicker system installation. The filter-drier is shipped loose for installation in the field. The unit is factory-charged for 15 ft refrigeration piping. The small base dimension and reduced unit clearances make for easier retrofits.
- **Accessible information** - QR code on unit provides quick access to technical documents and warranty information.
- **Durable finish** - The coated steel wire fan guard, coated external fasteners, and pre-treated G90-equivalent galvanized steel chassis components resist corrosion and rust creep. Modern Mist colored powdercoat paint further protects external panels.
- **Quality coils** - The high efficiency microchannel aluminum coil is manufactured using an improved material system, providing reliable performance and small unit size.
- **Rugged coil protection** - Coils are protected from mechanical damage by a proven stamped steel coil guard design.
- **Protected compressor** - Compressors are protected internally by a high-pressure relief valve and a temperature sensor, and externally by the system high-pressure switch.
- **Reliable operation** - Ball bearing fan motors provide superior performance in extreme temperatures.
- **Environmentally friendly** - CFC-free R-454B refrigerant delivers environmentally friendly performance with zero ozone depletion.
- **Top discharge** - Warm air is blown up, away from the structure and any landscaping, allowing compact location on multi-unit applications.
- **Low operating sound levels** - Developed using CFD and FEA tools, the sturdy cabinet and top design provides sound performance of 77 dBA or lower. Compatible accessories for further sound reduction are also available.
- **Better service access** - Diagonal base valves with open access for low-loss fittings, single panel access to the electrical controls, swing out control box for full corner access, and removable fan guard allow easy access for unit maintenance.
- **Agency listed** - Safety certified by CSA to UL 60335-2-40/CSA C22.2. Performance certified to ANSI/AHRI Standard 210/240 in accordance with the Unitary Small Equipment certification program.

Nomenclature

Table 1: Nomenclature for AC and HP R-454B units

Number	Category	Option	Description
1	Brand	Y	YORK
		X	Private brand
		R	OTC
2	Product type	C	AC
		H	HP
3	Nominal series efficiency	3	13.4 SEER2 LGWP
		4	14.3 SEER2 LGWP
		5	15.2 SEER2 LGWP
		6	16 SEER2 LGWP
		7	17 SEER2 LGWP
		8	18 SEER2 LGWP
		9	19 SEER2 LGWP
		V	20/21 SEER2 (DOE ccHP)
		X	22/23 SEER2
4, 5	Nominal unit capacity (MBH)	18	1.5 ton
		24	2 ton
		30	2.5 ton
		36	3 ton
		42	3.5 ton
		48	4 ton
		60	5 ton
6	Refrigerant	D	TBC
		E	R-454B
7	Voltage (voltage-phase-hertz)	2	208/230-1-60
		3	208/230-3-60
		4	460-3-60
		5	575-3-60
8	Control strategy	C	Communicating
		B	Wireless (communicating)
		S	Standard (conventional)
		W	Wireless (conventional)
9	Factory option	1	Standard (no options)
		2	Future use
10	Generation	1	First generation
		2	Second generation
11	Style letter (minor revision)	A	Style A
		B	Style B

Table 2: Model nomenclature example

Number	1	2	3	4, 5	6	7	8	9	10	11
Option	X	C	3	36	E	3	S	1	1	A

Physical and electrical data

Table 3: Physical and electrical data

Outdoor unit model	XC336E3S11	XC348E3S11	XC360E3S11	XC336E4S11	XC348E4S11	XC360E4S11	XC336E5S11	XC348E5S11	XC360E5S11
Unit supply voltage	208/230 V, 3 phase, 60 Hz			460 V, 3 phase, 60 Hz			575 V, 3 phase, 60 Hz		
Normal voltage range ¹ (V)	187—252			432—504			540—630		
Minimum circuit ampacity (A)	16.9	18.9	24.0	6.9	8.1	10.8	6.0	7.8	8.6
Maximum overcurrent device ² (A)	25	30	40	15	15	15	15	15	15
Minimum overcurrent device ³ (A)	20	20	25	15	15	15	15	15	15
Compressor type ⁴	Scroll	Scroll	Scroll	Scroll	Scroll	Scroll	Scroll	Scroll	Scroll
Compressor rated load	12.8	14.3	18.3	5.1	6.0	8.2	4.5	5.8	6.4
Compressor locked rotor	97.5	120.4	156.4	44.3	49.4	69.0	27.1	41.0	47.8
Crankcase heater	No	No	No	No	No	No	No	No	No
Factory external discharge muffler	No	No	No	No	No	No	No	No	No
Fan diameter (in.)	18	24	26	18	24	26	18	24	26
Fan motor rated HP	1/4	1/4	1/4	1/4	1/4	1/4	1/4	1/4	1/4
Fan motor rated load (A)	1.33	1.30	1.30	0.69	0.65	0.65	0.53	0.60	0.60
Fan motor nominal RPM	1100	850	850	1100	850	850	1100	850	850
Fan motor nominal CFM	2575	3500	4300	2575	3500	4300	2575	3500	4300
Coil face area (sq. ft.)	13.84	18.70	23.33	13.84	18.70	23.33	13.84	18.70	23.33
Coil rows deep	1	1	1	1	1	1	1	1	1
Coil fins per inch	23	23	23	23	23	23	23	23	23
Liquid refrigerant piping outdoor unit (field installed)	3/8	3/8	3/8	3/8	3/8	3/8	3/8	3/8	3/8
Vapor refrigerant piping outdoor unit (field installed) ⁵	3/4	7/8	1 1/8‡	3/4	7/8	1 1/8‡	3/4	7/8	1 1/8‡
Unit charge ⁷ (lb-oz)	2 - 14	3 - 4	3 - 10	2 - 14	3 - 4	3 - 10	2 - 14	3 - 4	3 - 10
Charge (oz/ft)	0.57	0.60	0.67	0.57	0.60	0.67	0.57	0.60	0.67
Operating weight (lb)	140	230	255	140	230	255	140	230	255

Physical and electrical data notes

1. Rated in accordance with AHRI Standard 110-2012, utilization range A.
2. Dual element fuses or HACR circuit breaker. Maximum allowable overcurrent protection.
3. Dual element fuses or HACR circuit breaker. Minimum recommended overcurrent protection.
4. For applications with non-standard vapor line sizes, see *Applications and accessories*.
5. The unit charge is correct for the outdoor unit, smallest matched indoor unit, and 15 ft of refrigerant tubing. For tubing lengths other than 15 ft, add or subtract the amount of refrigerant, using the difference in actual refrigeration piping length (not the equivalent length) multiplied by the per foot value.

‡ The adapter fitting must be field installed for the required 1 1/8 in. refrigeration piping.

Dimensions

Table 4: Dimensions

Outdoor unit model	Installed height (in.)	Installed depth (in.)	Installed width (in.)	Refrigerant liquid service valve (in.)	Refrigerant vapor service valve (in.)
XC336E3S11	36 1/4	24	24	3/8	3/4
XC336E4S11					
XC336E5S11					
XC348E3S11	33 1/4	35 1/4	31 3/4		7/8
XC348E4S11					
XC348E5S11					
XC360E3S11	36 1/4	38	34 1/4	7/8‡	
XC360E4S11					
XC360E5S11					

Illustration of dimensions

Figure 2: Unit dimensions

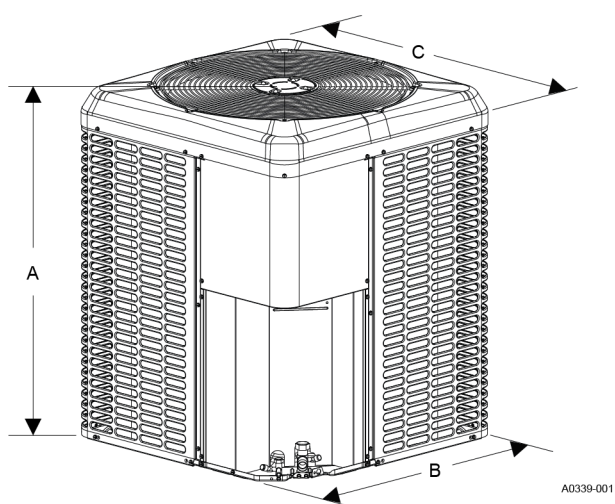

Dimensions data notes

‡ The adapter fitting must be field-installed for the required 1 1/8 in. refrigeration piping.

- All dimensions are in inches and are subject to change without notice.
- The overall height is from the bottom of the base pan to the top of the fan guard.
- The overall length and width include screw heads.

System charge table

Table 5: System charge table

Outdoor unit model	XC336E3S11, XC336E4S11 and XC336E5S11	XC348E3S11, XC348E4S11 and XC348E5S11	XC360E3S11, XC360E4S11 and XC360E5S11
Required metering device ^{1,2}	5C1	5C1	5C1
Indoor coil model ^{3,4,5}	Additional charge (oz)		
JHE18B**B	—	—	—
JHE24B**C	—	—	—
JHE30B**D	—	—	—
JHE36(B,C)**D	12	—	—
JHE42C**F	—	—	—
JHE48(C,D)**G	—	16	—
JHE60(C,D)**H	—	—	23
JHC18B**B	—	—	—
JHC24B**C	—	—	—
JHC36(B,C)**D	—	—	—
JHC42(C,D)**F	—	—	—
JHC48(C,D)**G	—	16	—
JHC60(C,D)**H	—	—	23
CT(F,M,U)18A**A	—	—	—
CTF18B**A	—	—	—
CT(F,M,U)24A**B	—	—	—
CT(F,M)24B**B	—	—	—
CTF30A**D	—	—	—
CT(F,M,U)30B**C	—	—	—
CT(F,M)30C**C	—	—	—
CT(F,M,U)36B**D	12	—	—
CTF36B**E	14	—	—
CT(F,M)36C**D	12	—	—
CTF42C**E	14	—	—
CTM42C**E	14	—	—
CT(F,M,U)48C**F	—	12	—
CT(F,M)48D**F	—	12	—
CT(F,M,U)60C**G	—	16	19
CT(F,M,U)60D**G	—	16	19
CT(F,M)60C**H	—	—	23
CT(F,M,U)60D**H	—	—	23
CXF36(B,C)**4	0	—	—
CXF42C**5	1	—	—
CXF48(C,D)**6	—	0	—
CXF60(C,D)**7	—	1	0

System charge data notes

1. For applications requiring a TXV, use S1-1TVM*** series kit.
2. Use a TXV kit with these indoor units to obtain system performance.
3. Systems matched with furnaces or air handlers not equipped with blower-off delays may require blower time delay.
4. Do not use CTF, CTU, or CXF coils in horizontal applications. CTM coils can be used in horizontal, upflow, or downflow applications.

5. Charge adders shown above do not indicate that coils are rated for every application. See the *Performance data* tables for actual performance for specified system matches. Obtain certified system ratings from <http://www.ahridirectory.org>.

Charging

1. Check the factory unit charge listed on the unit nameplate to verify the refrigerant charge for the outdoor unit, the smallest matched indoor unit, and the 15 ft of interconnecting refrigeration piping.
2. Verify the indoor metering device and additional charge required for the specific matched indoor unit in the system using the *System charge* table.
3. Add additional charge for the amount of interconnecting refrigeration piping greater than 15 ft at the rate specified in the *Physical and electrical data* table.
4. For installations requiring additional charge, weigh in refrigerant for the specific matching indoor unit and actual refrigeration piping length.
5. After weighing in the charge adders for the matched indoor unit and refrigeration piping, verify the system operation against the temperatures and pressures in the charging chart for the outdoor unit. Locate the charging charts on the outdoor unit and in the *Service Data Application Guide* at www.simplygettingthejobdone.com. Follow the subcool or superheat charging procedure in the *Installation Manual* according to the type of indoor metering device in the system, and allow 10 min after each charge adjustment for the system operation to stabilize. Record the charge adjustment made to match the charging chart.
6. Permanently stamp the unit nameplate with the total system charge defined as follows: total system charge = base charge (as shipped) + charge adder for matched indoor unit + charge adder for actual refrigeration piping length + charge adjustments to match the charging chart.

Applications and accessories

Refer to the *Price Manual* for specific model numbers.

Table 6: Standard application limits

Standard application limits		
Maximum refrigeration piping equivalent length		80 ft
Outdoor ambient temperature limits		
Cooling operation	Maximum DB	115°F
	Minimum DB	55°F

Note: For low ambient and long refrigeration piping applications, see the accessories listed below.

Non-standard refrigeration piping applications: For installations with reduced diameter or long refrigeration piping, refer to the current version of the *Piping Application Guide* P/N 247077, available in the *Application Bulletins* section at www.simplygettingthejobdone.com.

OD unit anti-short cycle kit (10 Pack) (S1-2TD08700124BK): A time delay that prevents rapid compressor restarting as a result of power interruption, limit switch operation, or thermostat resetting. Not required for AC models with factory electronic controls.

Standard low ambient control kit (S1-2LA06700424): Allows the use of air conditioning at low outdoor ambient temperatures down to +20°F (-7°C). For use with all R-454B single-stage AC models.

Advanced low ambient control kit (S1-2LA04701024): Contains the necessary components and controls to allow cooling operation down to -20°F (-29°C). For use with some R-454B single-stage AC and HP models. This accessory can only be applied to models that contain a PSC outdoor fan motor.

Low pressure switch kit (S1-2PS06700524): Provides field installed low pressure (loss of charge) protection. Not required for AC models with factory electronic controls.

High ambient outdoor fan motor (S1-FHM**HT):** Class F 70°C motor to allow cooling operation up to 160°F air entering the outdoor coil. For use with all R-454B single-stage AC models containing R-454B refrigerant only.

Compressor crankcase heater kit (S1-025-***-***):** A wrap-around electrical resistance heater that warms the compressor sump, reducing the chance of liquid slugging on startup. Required on all long lineset and low ambient applications. Refer to the *Price Pages* or *Source 1 SmartSearch* for the correct part for each application.

Anchor bracket kit (S1-1HK0601): Firmly anchors unit to pad or support structure. When correctly installed, approved for ground-mounted or roof-mounted applications.

Indoor TXV kit (S1-1TVM*):** Thermal expansion valves precisely meter refrigerant for optimum performance over a wide range of conditions. See the *System charge* table or refer to the *Price Pages* or *Source 1 Smart Search* for the TXV part number for each AC model.

Winter cover kit (S1-CCVRE*):** Custom fit winter cover protects AC outdoor unit from debris during the off-season. Remove before unit operation. Refer to the *Price Pages* or *Source 1 SmartSearch* for the correct cover for each application.

Touch-up paint (S1-5130153**):** Color matched aerosol paint for touching up unit chassis and panels. Refer to the *Price Pages* or *Source 1 SmartSearch* for the correct color for each application.

Compressor sound blanket (S1-01007xxx000): A field installed dense foam cover that provides 2 dBA sound level reduction. Refer to the *Price Pages* or *Source 1 SmartSearch* for the correct blanket for each application.

Thermostat: Compatible thermostat controls are available through accessory sourcing. For optimum performance, these outdoor units are fully compatible with our residential Hx™ Touch Screen Thermostat available through Source 1. For more information, refer to the *Thermostats & Controllers* section at www.simplygettingthejobdone.com.

Sound power rating

Table 7: Sound power data- stage 2- Cooling – Octave band sound power level (db re. 1-pW)

Outdoor unit model	Power level 63 (Hz)	Power level 125 (Hz)	Power level 250 (Hz)	Power level 500 (Hz)	Power level 1000 (Hz)	Power level 2000 (Hz)	Power level 4000 (Hz)	Power level 8000 (Hz)	dBA	SQI
XC336E3S11	72	73	68	70	68	66	60	64	74	19.0
XC348E3S11	68	70	70	70	69	63	61	61	76	19.2
XC360E3S11	70	73	72	71	71	66	64	64	77	19.1
XC336E4S11	72	73	68	70	68	66	60	64	74	19.0
XC348E4S11	68	70	70	70	69	63	61	61	76	19.2
XC360E4S11	70	73	72	71	71	66	64	64	77	19.1
XC336E5S11	72	73	68	70	68	66	60	64	74	19.0
XC348E5S11	68	70	70	70	69	63	61	61	76	19.2
XC360E5S11	70	73	72	71	71	66	64	64	77	19.1

Mechanical specifications

Manufacture and certifications

- Units shall be assembled at a facility with an ISO 9001:2015-certified Quality Management System.
- Units shall be certified by CSA to UL 60335-2-40/CSA C22.2 and performance certified to ANSI/AHRI Standard 210/240.
- Units shall be sound tested according to ANSI/AHRI Standard 270.
- Certified matched system ratings shall be available for download from the AHRI online directory at www.ahridirectory.org.

Unit application

- Units shall be approved for cooling operation between 55°F and 125°F without modification.
- Units shall be approved for linesets up to 80 ft equivalent length without modification.
- Units shall be approved for installation within 6 in. of a flat vertical wall without modification, according to the instructions in the technical literature.
- Units shall be designed to 77 dBA or less to minimize sound pollution.

Unit access

- Units shall have a removable fan guard that can be removed independently of the top for interior access through the top of the unit without damaging the coil.
- Units shall have two removable stamped steel coil guards for exterior coil access.
- Units shall have a separate compartment for electrical controls that can be accessed without disturbing the unit airflow.
- Units shall have a blockoff panel that can be removed to provide interior unit access through the side of the unit.
- Units shall have a removable blockoff panel and a swing away removable electrical panel that provides sufficient interior unit access for removing the compressor through the side of the unit.

Unit construction

- Units shall be shipped completely wired, piped, and assembled. Wiring pigtails shall be provided for field control wiring connections. Service valves shall be provided for field refrigerant line connections.
- Units shall be factory leak checked, run tested, and shipped with a holding charge of R-454B refrigerant.
- Unit cabinet components shall be G90 equivalent steel finished with powder-coat paint rated at a minimum of 500 h under ASTM B117 testing.
- Unit base pan shall be stamped G90 equivalent steel finished with powder-coat paint rated at a minimum of 500 h under ASTM B117 testing.
- Units shall have a single corner post opposite the electrical control box and two independently removable steel coil guard panels to optimize cabinet strength and serviceability.
- Units shall have L-shaped stamped sheet metal coil guards with punched and extruded slots for maximum panel durability and stiffness.
- Unit base valves shall be mounted diagonally on the unit base pan with service ports that provide sufficient clearance for low-loss hose fittings.
- Units shall be constructed with a high-pressure switch for system protection.
- Units shall be constructed with all badging and labels applied at the factory.

Unit components

- Compressor shall be hermetic with internal electrical overload protection and internal overpressure protection.
- Compressor shall be mounted on rubber vibration isolators that do not require the removal of transportation clips or brackets.
- Outdoor fan shall be direct drive with vertical air discharge for low sound levels.

Mechanical specifications

- Outdoor fan motor shall be totally enclosed with permanently lubricated ball bearings motors approved for vertical shaft applications.
- Outdoor coil shall be air cooled and have zinc-coated aluminum microchannel construction for small size and low weight.

Unit warranties

- Unit manufacturer shall provide a 5-year limited compressor warranty without a requirement for unit registration.
- Unit manufacturer shall provide a 1-year limited parts warranty without a requirement for unit registration.

Typical installation

Figure 3: Typical installation

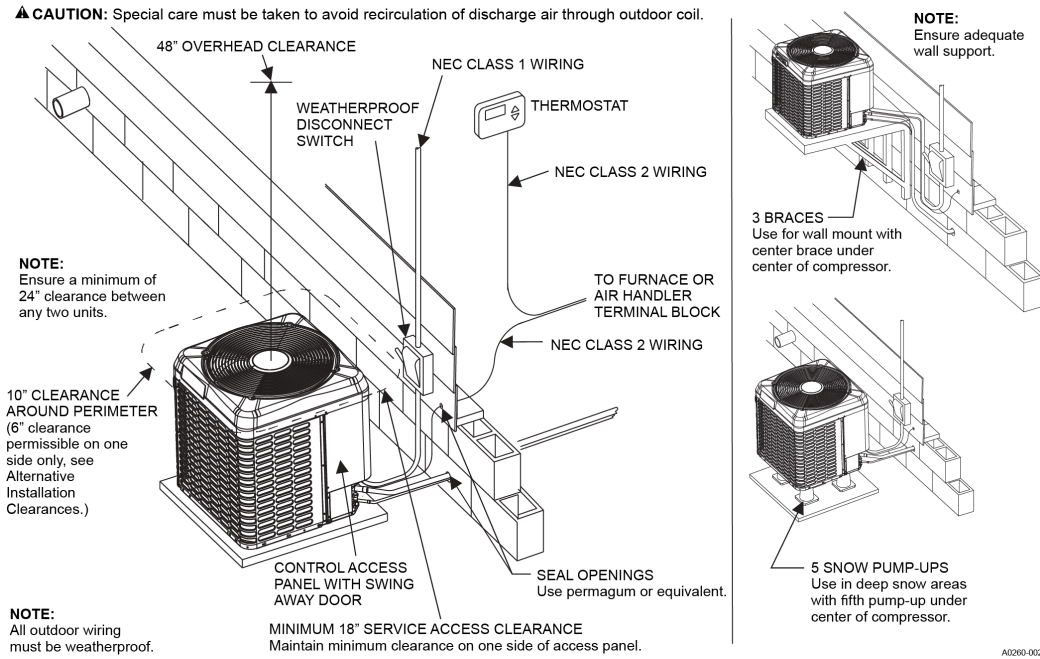

CAUTION

Care must be taken to prevent ice from damaging the unit. Damage may occur from ice falling onto unit from a sloped roof or from a vertical drip line due to a partial overhang.

Figure 4: Typical installation

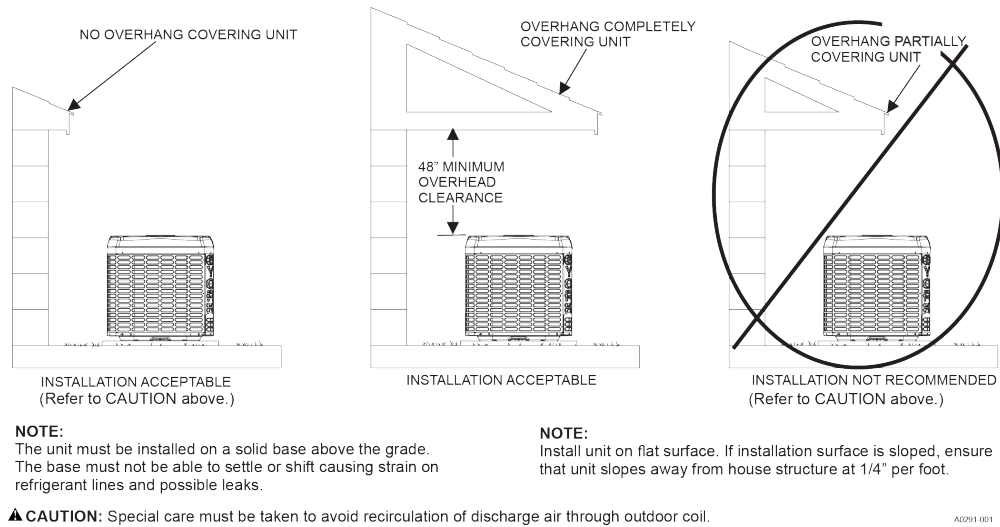

Alternative installation clearances

Figure 5: Alternative installation clearances

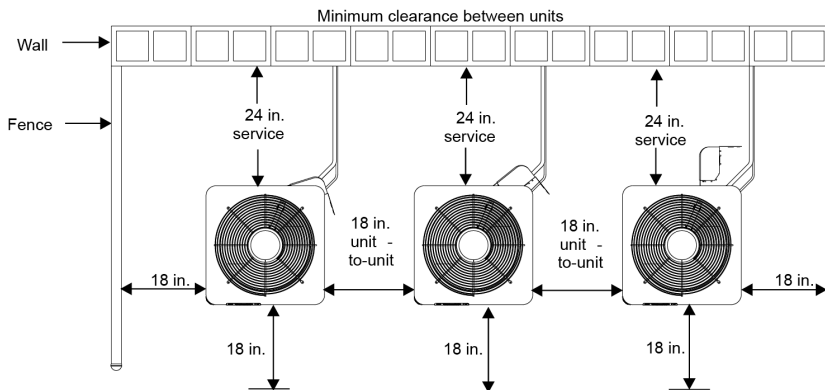

Note:
Clearance between two units may be reduced to 18 in. minimum provided the service access clearance is increased to 24 in. minimum, and the clearance on each remaining side is maintained at 18 in. minimum.

Note:
Clearance to one side of the unit may be reduced to 6 in. provided the clearance to each remaining side is increased to 12 in. minimum, the service access is increased to 24 in. minimum, and the clearances between any two units is maintained at 24 in. minimum.

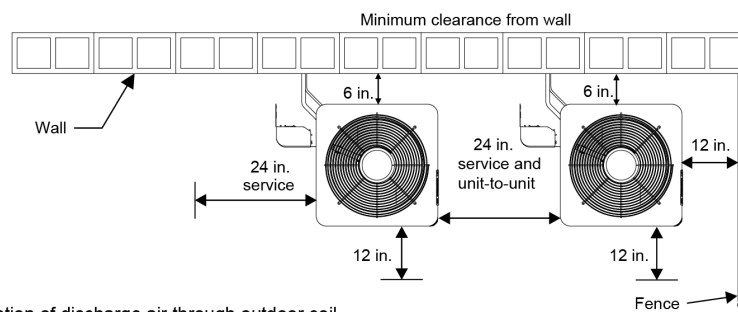

CAUTION:
Special care must be taken to avoid recirculation of discharge air through outdoor coil.

A0287-001

Performance data - 3 ton

See the following tables for performance data for the XC336E3S11, XC336E4S11, and XC336E5S11 units.

Cooling performance data - 3 ton

Table 8: Cooling performance data - 3 ton

Air temperature entering outdoor unit (°F)	Indoor CFM	1000					1200					1400						
		Indoor dry bulb (°F)		80	80	75	80	80	80	80	75	80	80	80	80	75	80	80
		Indoor wet bulb (°F)		57	62	62	67	72	57	62	62	67	72	57	62	62	67	72
55	Total capacity	32.9	35.3	35.2	38.4	41.1	34.6	36.3	36.3	39.7	42.5	35.8	37.0	37.1	40.6	43.4		
55	Sensible capacity	32.6	29.9	25.3	24.8	19.6	34.2	32.6	27.2	26.6	20.8	35.4	35.0	29.0	28.2	21.8		
55	kW	1.98	1.99	1.99	1.99	2.00	2.08	2.09	2.09	2.09	2.10	2.17	2.18	2.19	2.19	2.20		
65	Total capacity	32.3	34.6	34.5	37.6	40.9	33.9	35.3	35.4	38.5	41.7	35.1	35.8	35.9	39.1	42.4		
65	Sensible capacity	31.9	29.2	24.9	24.8	20.2	33.5	31.7	26.6	26.4	21.2	34.7	33.8	28.0	27.8	22.1		
65	kW	2.28	2.27	2.27	2.25	2.22	2.35	2.35	2.35	2.33	2.31	2.43	2.43	2.43	2.42	2.40		
75	Total capacity	31.4	33.2	33.2	36.2	39.5	32.9	33.9	34.0	37.0	40.3	34.1	34.3	34.5	37.6	40.8		
75	Sensible capacity	31.0	28.9	24.4	24.4	19.8	32.6	31.4	26.1	26.1	20.8	33.7	33.3	27.6	27.6	21.6		
75	kW	2.47	2.46	2.46	2.46	2.45	2.56	2.56	2.56	2.55	2.54	2.64	2.64	2.65	2.64	2.63		
85	Total capacity	30.3	31.7	31.7	34.7	37.9	31.8	32.3	32.4	35.5	38.5	32.9	32.9	32.9	35.9	39.0		
85	Sensible capacity	30.0	28.4	23.8	23.8	19.2	31.4	30.8	25.6	25.6	20.2	32.5	32.5	27.2	27.1	21.1		
85	kW	2.69	2.69	2.69	2.69	2.69	2.79	2.79	2.79	2.79	2.78	2.87	2.87	2.87	2.87	2.87		
95	Total capacity	29.2	30.3	30.3	33.4	36.3	30.6	30.9	31.0	34.0	37.0	31.6	31.7	31.3	34.4	37.3		
95	Sensible capacity	28.9	27.8	23.2	23.2	18.6	30.2	29.9	24.9	24.9	19.5	31.3	31.3	26.6	26.4	20.4		
95	kW	3.00	3.00	3.00	3.01	3.01	3.09	3.09	3.09	3.09	3.10	3.18	3.18	3.18	3.18	3.18		
105	Total capacity	27.9	28.7	28.7	31.6	34.5	29.2	29.3	29.3	32.2	35.1	30.2	30.2	29.7	32.5	35.4		
105	Sensible capacity	27.6	26.9	22.4	22.4	17.9	28.9	28.9	24.2	24.1	18.9	29.8	29.8	25.8	25.6	19.7		
105	kW	3.36	3.36	3.36	3.37	3.38	3.46	3.46	3.46	3.47	3.48	3.55	3.55	3.55	3.56	3.57		
115	Total capacity	26.6	26.6	26.6	29.1	31.1	27.8	27.9	27.3	30.1	32.5	28.6	29.0	27.8	30.9	33.7		
115	Sensible capacity	26.2	26.2	22.1	21.3	15.7	27.4	27.6	24.0	23.2	17.2	28.2	28.6	25.6	25.1	18.5		
115	kW	3.82	3.82	3.81	3.84	3.86	3.88	3.89	3.88	3.92	3.95	3.95	3.97	3.96	3.99	4.03		
125	Total capacity	22.9	23.0	22.9	25.5	28.0	24.9	25.1	24.2	26.8	29.4	26.7	26.8	25.2	27.9	30.5		
125	Sensible capacity	22.6	22.8	19.3	19.1	14.9	24.6	24.8	22.0	21.7	16.2	26.4	26.5	24.3	24.1	17.5		
125	kW	4.76	4.78	4.79	4.82	4.86	4.64	4.68	4.68	4.73	4.80	4.57	4.63	4.66	4.69	4.77		

Performance data - 4 ton

See the following tables for performance data for the XC348E3S11, XC348E4S11, and XC348E5S11 units.

Cooling performance data - 4 ton

Table 9: Cooling performance data - 4 ton

Air temperature entering outdoor unit (°F)	Indoor CFM Indoor dry bulb (°F) Indoor wet bulb (°F)	1350					1550					1750				
		80	80	75	80	80	80	80	75	80	80	80	80	75	80	80
		57	62	62	67	72	57	62	62	67	72	57	62	62	67	72
55	Total capacity	44.6	46.9	46.7	49.8	52.8	46.1	47.9	47.6	51.0	54.1	47.3	48.5	48.3	52.0	55.1
55	Sensible capacity	44.6	40.1	33.8	32.4	24.5	46.1	42.5	35.5	34.2	25.9	47.3	44.7	37.0	35.9	27.2
55	kW	2.69	2.70	2.70	2.71	2.72	2.78	2.79	2.79	2.80	2.82	2.87	2.88	2.88	2.90	2.91
65	Total capacity	42.4	45.4	45.2	49.3	53.6	44.1	46.3	46.1	50.2	54.4	45.5	46.8	46.8	50.9	55.1
65	Sensible capacity	42.4	39.2	33.0	32.7	26.2	44.1	41.7	34.7	34.5	27.2	45.5	43.9	36.4	36.0	28.1
65	kW	2.97	2.97	2.97	2.98	2.99	3.07	3.07	3.08	3.08	3.09	3.16	3.16	3.16	3.17	3.18
75	Total capacity	42.0	44.6	44.4	48.5	52.7	43.6	45.3	45.2	49.4	53.5	44.9	45.8	45.8	49.9	54.2
75	Sensible capacity	42.0	39.4	33.0	32.8	26.2	43.6	41.7	34.8	34.6	27.3	44.9	43.9	36.5	36.2	28.2
75	kW	3.29	3.29	3.29	3.30	3.31	3.38	3.38	3.38	3.39	3.40	3.47	3.47	3.47	3.48	3.49
85	Total capacity	41.1	43.2	43.2	47.2	51.4	42.6	43.9	43.9	48.0	52.2	43.9	44.3	44.4	48.6	52.7
85	Sensible capacity	41.1	39.0	32.8	32.5	25.9	42.6	41.3	34.3	34.3	27.0	43.9	43.5	36.1	36.0	27.9
85	kW	3.64	3.65	3.65	3.66	3.67	3.75	3.75	3.75	3.76	3.77	3.84	3.84	3.84	3.85	3.86
95	Total capacity	39.6	41.4	41.3	45.3	49.3	41.0	42.0	41.9	46.0	50.0	42.2	42.3	42.4	46.4	50.6
95	Sensible capacity	39.6	37.9	31.7	31.6	25.0	41.0	40.3	33.4	33.4	26.1	42.2	42.3	35.1	34.9	27.0
95	kW	4.07	4.07	4.07	4.09	4.10	4.16	4.16	4.16	4.18	4.19	4.25	4.25	4.26	4.27	4.28
105	Total capacity	37.9	39.0	39.0	42.9	46.7	39.2	39.4	39.6	43.5	47.4	40.3	40.3	40.0	43.9	47.9
105	Sensible capacity	37.9	37.0	30.6	30.7	24.1	39.2	39.3	32.6	32.4	25.2	40.3	40.3	34.3	34.1	26.1
105	kW	4.58	4.58	4.59	4.60	4.62	4.68	4.68	4.68	4.69	4.71	4.77	4.77	4.76	4.78	4.80
115	Total capacity	35.1	36.0	36.1	39.9	43.8	36.3	36.9	36.8	40.7	44.9	37.4	38.0	37.1	41.3	45.5
115	Sensible capacity	35.1	35.1	29.1	29.1	22.5	36.3	36.9	31.2	31.5	24.3	37.4	38.0	33.0	33.8	26.0
115	kW	5.27	5.24	5.25	5.23	5.21	5.33	5.32	5.32	5.31	5.30	5.41	5.41	5.41	5.37	5.38
125	Total capacity	32.7	33.1	33.1	36.7	40.3	33.9	34.5	33.6	37.5	41.2	35.0	35.6	34.1	38.0	42.0
125	Sensible capacity	32.7	33.1	27.9	28.1	21.8	33.9	34.5	29.9	30.5	23.3	35.0	35.6	32.0	32.5	24.9
125	kW	6.23	6.12	6.13	6.09	6.05	6.23	6.17	6.17	6.12	6.13	6.26	6.23	6.23	6.21	6.20

